

# Brush Belt System Automatic

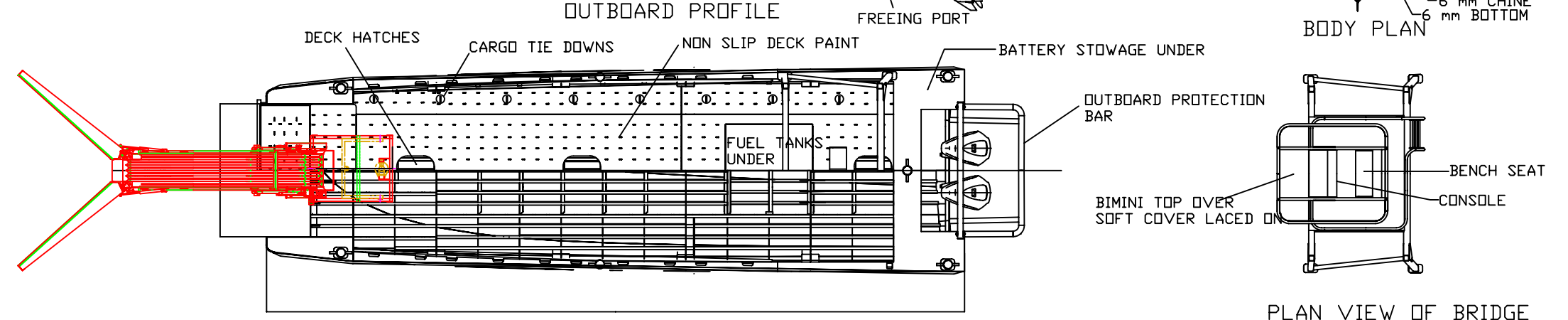

PLAN VIEW OF BRIDGE

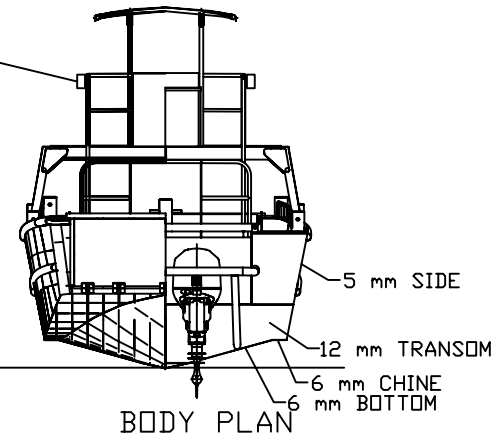
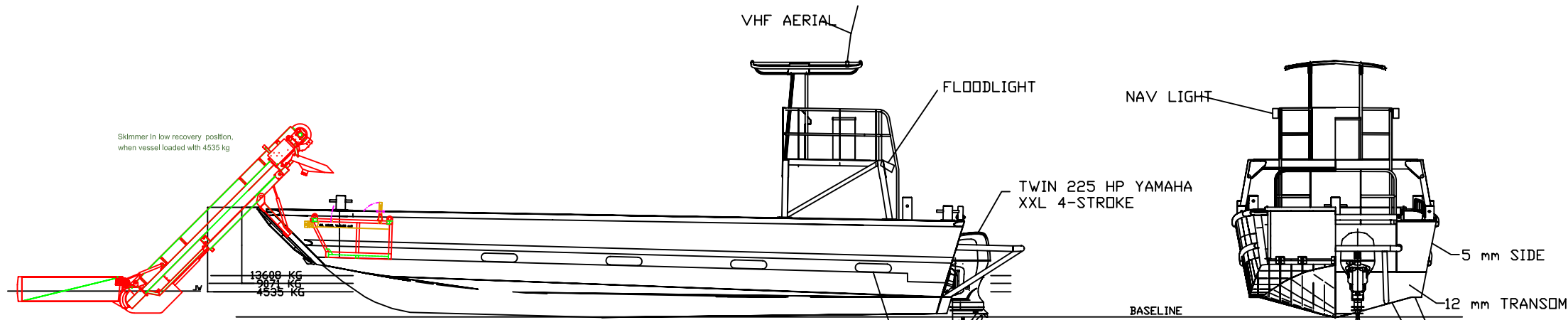
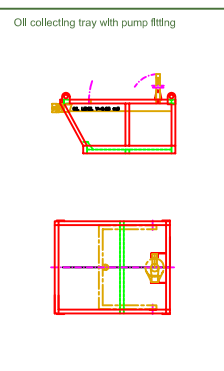
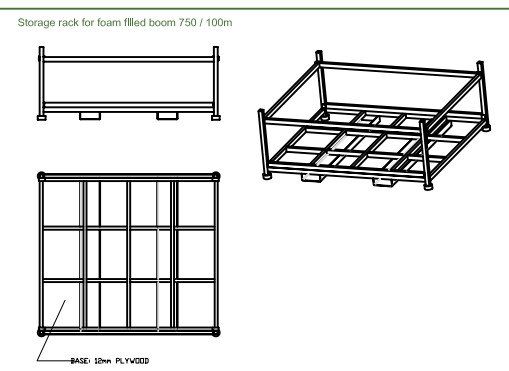
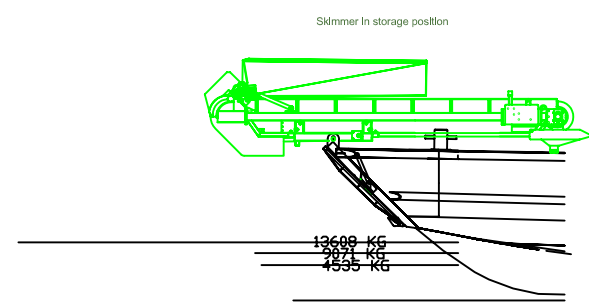
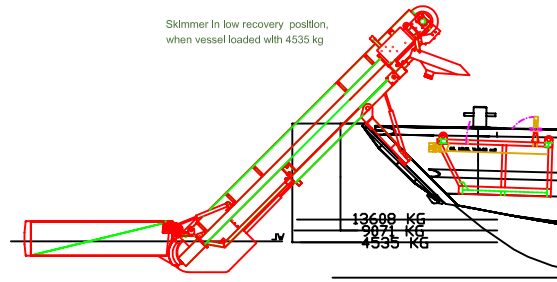
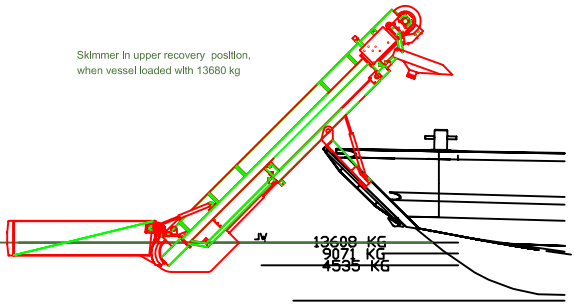
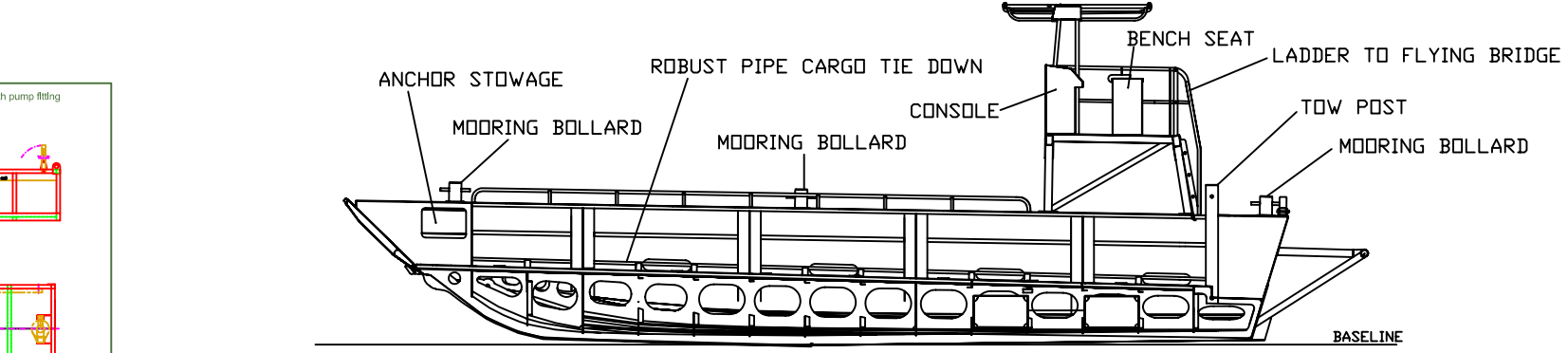

INBOARD PROFILE

12.6M LANDING CRAFT FOR OIL RECOVERY WORK, IRAQ  
WORKING BOATS UK LTD  
07/02/06  
COPYRIGHT